

Maximize Your Tubular Connections

Increased Productivity through Enhanced Safety

Safer tubular connection operations

By significantly reducing exposure to safety risks, crew personnel can focus on the tubular requirements to achieve a high integrity connection. Eckel provides a variety of Safety Enhanced features to mitigate safety risks in return that reduce operational costs through preventative accidents, rig time, and connection failure.

Let an Eckel tong maximize your next casing job.

Safety
Enhanced



ECKEL 7⁵/₈ HDS-35
CASING TONG

MAX TORQUE
35K FT-LBS

RPM **110** | **56**
@65 GPM **20** | **10**

1. Enhanced Safety Paint Scheme

OSHA and ANSI Z535.1-2017 safety colors. Descriptive factory paint markings to visually communicate best operating practices to personnel.

2. Control Valve Bank Protection

Rigid protective bar to prevent damage or accidental actuation of levers.

3. Tong Positioning Straps

Industrial strength straps with rubber gripping surface for pulling the tong on and off tubulars.

4. Head Retraction System

Automatically retraction of pivot heads to their ready point after torque operations are completed. A standard feature for tongs with sliding heads.

5. Safety Stickers

Identification of potential hazards when operating the equipment.

6. Spring Cover Guard

Mitigates pinch points for personnel, sleeves are fitted over backup springs.

7. Door Finger Guard Shield

Rubber guard to mitigate pinch points when manually operating tong door.

8. Door Interlock

Prevents accidental operation of the tong when the door is open.

9. Tong Positioning Handles

Providing safe contact locations on the tong for maneuvering the tong on and off tubulars.

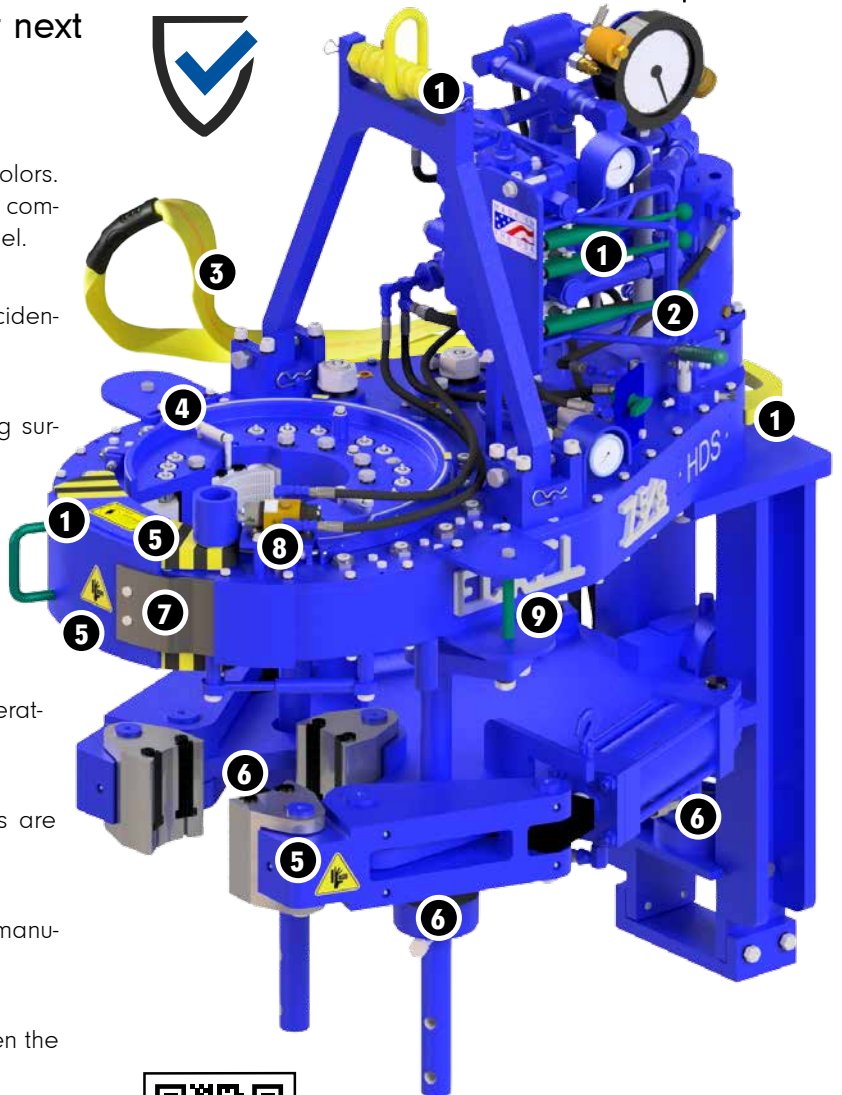

SCAN ME

ECKEL[®]

HYDRAULIC POWER TONGS

www.eckel.com | sales@eckel.com

RELIABLE • SAFE • EFFICIENT • TRUSTED

For more information visit: WWW.ECKEL.COM